

WEDGE WIRE SCREENS **Filtrindustries**

Filtrindustries is capable of adapting product design to your specific application and bring you to the ideal solution for a wide range of processes.

Separating, retaining, filtering, sieving, dewatering, collecting and distributing are the most common tasks our wedge wire screens can perform for numerous industries.

TYPES:

- Pipe base laterals
- Screen laterals
- Header and hub laterals
- Nozzles and inlet distributors
- Custom nozzles
- Resin traps
- Baskets strainer
- Custom support grids (flat or round)

CHARACTERISTICS AND ADVANTAGES:

- High dirt holding capacities
- Really high collapse ratings
- Easy to clean and wash
- Many types of stainless and alloys available
- Reasonable and accurate costing
- Rapid estimates and lead times

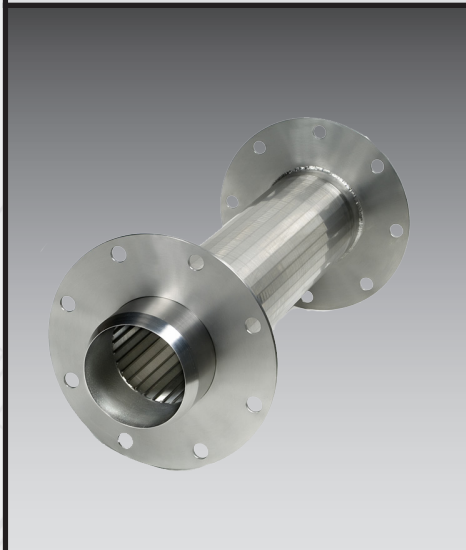

**INDUSTRIAL
FILTRATION
SOLUTIONS**

T 418 832-1415 1 888-FILTRES (345-8737)

filtrindustries.com
ventes-sales@filtrindustries.com

